



**LUXAIR**<sup>TM</sup>  
EXTRACTION WITH ATTRACTION

# LA-Titan



Reducer Collar reduces the motor exhaust from 150mm to 125mm if required (Already supplied in box)

\*\*Please note this hood must be installed on a minimum of 125mm Ducting - We highly recommend 150mm\*\*

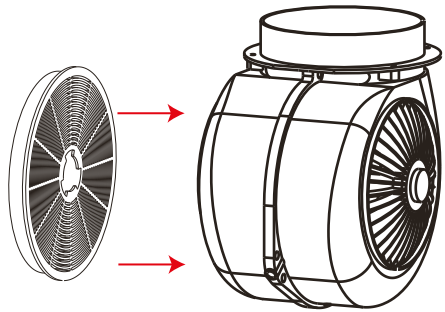

Spare Motor 950 m<sup>3</sup>/hr  
- 'A' Rated Energy Efficient  
- Fits Models 90cm

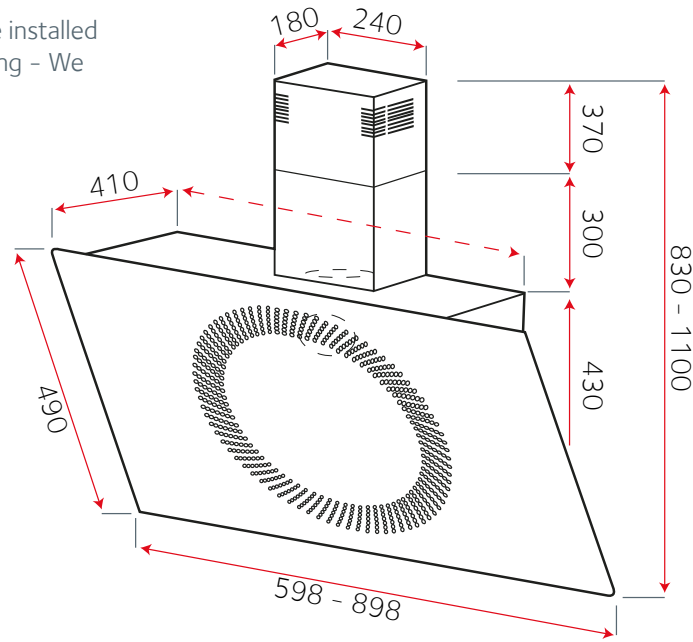

Replacement Switch  
- Electronic Touch Control

\*\*Please contact Luxair for further information\*\*

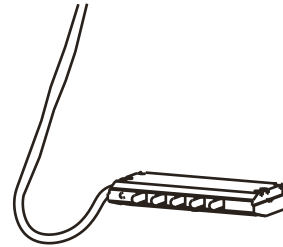

LED Driver

\*\*Please contact Luxair for more information\*\*

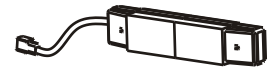

2x 3w LED Down Lights

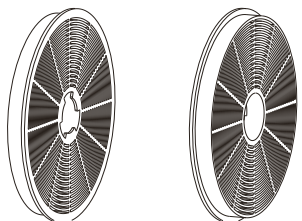

2x Charcoal Filter 5

(2 Filters Per Pack, 1 either side of Motor)

Mesh Grills (current Models)

LA-60-Titan	x1	577x295
LA-90-Titan	x1	577x295

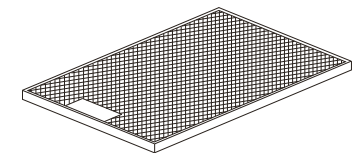

\*\*Please note you must measure your mesh grill size. Older models will have different sizes to current models\*\*

tt